

# iQ ESD™

## DAYLIGHT & UV MAGNIFIER

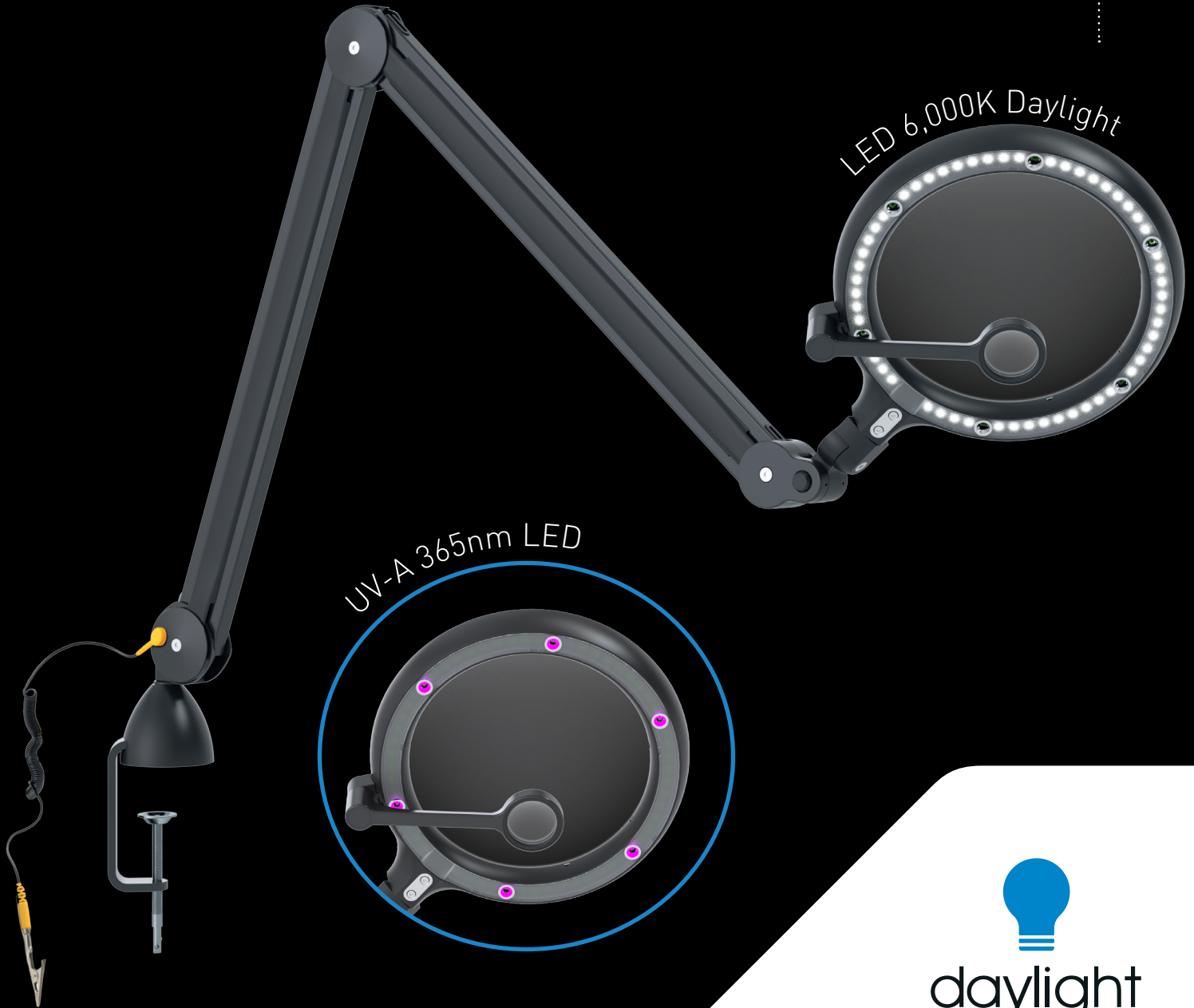

Fact Sheet



The iQ ESD™ is a 100% ESD-safe illuminated magnifier, independently certified for use in EPA (Electrostatic Protected Areas) to IEC 61340-5-1 & ANSI/ESD 20:20. A fantastic 2-in-1 light source, powerful Daylight 6,000K LEDs ensure clarity and shadow-free illumination while UV-A (365nm) LEDs are ideal for conformal coating inspection as well as thorough checking of soldered joints, welds and any other mechanical stress areas. With 2 brightness levels to suit your tasks, joints that hold any position and a large 17.5cm lens, the iQ ESD™ is the ultimate 2-in-1 ESD-safe illuminated magnifier.

LED 6,000K daylight

6,000 Lux at 15cm

UV-A (365nm) LEDs



LIGHT QUALITY



ERGONOMICS



DESIGN

[daylightcompany.com](http://daylightcompany.com)

# iQ ESD™

E25101

## DAYLIGHT & UV MAGNIFIER

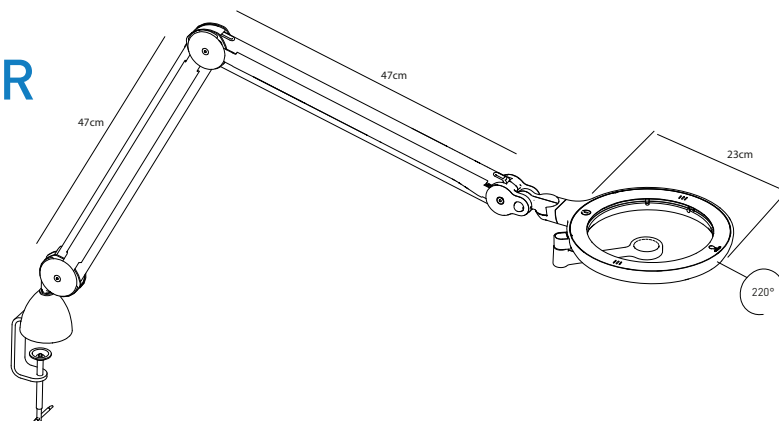

## FEATURES

- 2-in-1 light source: powerful Daylight 6,000K LEDs and UV-A (365nm) LEDs
- 100% ESD-safe illuminated magnifier that is independently certified
- Optical quality glass lens 17.5cm
- 3 dioptres magnification (1.75X) supplied with additional 12 dioptres (4X) swing arm magnifier
- Exceptionally strong and durable carbon fibre head and joint hold any position
- 2 brightness levels to adapt the lighting to your task at hand
- Long reach of 118cm so you position light exactly where you need it
- 3-year guarantee

## SPECIFICATIONS

### Product information

Weight	3.8kg
Colour	Black
Cable length	2m

### Packaging information

Height	61cm
Width	53cm
Depth	10cm
Packed weight	5kg
Products per master carton	2

### Light output

Daylight light source	LED
Lumens	700lm
Lux at 15cm	6,000 and 4,000
Colour temperature	6,000K
CRI	95+
UV light source	LED UV-A
UV wavelength	365nm
Energy consumption	12W