

Order no. 1005



## ZIEH-FIX® Bell

The ZIEH FIX® Bell can be used for tearing (pulling) of profile and round cylinders.  
With an additional plug extractor plate the tool can also be used for plug extraction.

### Basics

#### 1. Spray oil to be applied into keyway

The spray oil in the keyway eases the following insertion of the Pull Screws and decreases the danger of torsion breakage (weakening of material due to twisting). To avoid stains on the door surface remove overflowing oil straight away or cover with cleaning cloth.

#### 2. Screw in Pull Screw

The self-cutting ZIEH FIX® Pull Screws can be inserted into the keyway either with an appropriate tool (Torx size Tx20) or with an accu screw-driver and Torx-Bits.

The Pull Screw must be screwed in axial and in centre to the cylinder core.

The depth should be according to the key length. As a rough guide: 3-5 screw thread turns should still be visible outside the lock cylinder.

Depending on the quality of the lock cylinder or the size of the keyway differently sized Pull Screws can be used.

We recommend before using a Pull Screw with a large diameter to use a Pull Screw with a smaller diameter for "pre-drilling".

Example: Due to the quality of a lock cylinder the core should be pulled with a Pull Screw "Super" (Ø diameter 4.8 mm).

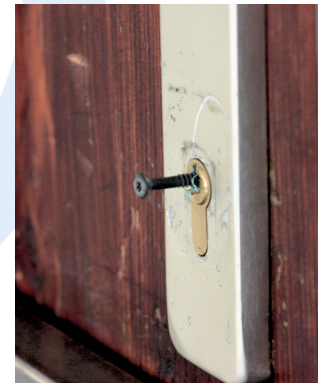

Picture 1

#### The correct step-by-step mode of operation would be:

1. Insertion of Cutting and Lubricating Spray
2. Pre-screwing with Pull Screw "Extra" (Ø diameter 4.2 mm)
3. Insertion of Cutting and Lubricating Spray
4. Attaching the pulling devise with Pull Screw "Super" (Ø diameter 4.8 mm)

For pre-screwing the Pull Screws can be used several times. For pulling the Pull Screws should only be used once to avoid breakage due to fatigue of material!

#### When do I use which screw?

**ZIEH FIX® Pull Screw 1202** „Extra” (yellow, Ø 4.2 mm)  
– for pre-drilling or breaking off old lock cylinders

**ZIEH FIX® Pull Screw 1203** „Super” (green, Ø 4.8 mm)  
– for breaking off old lock cylinders

**ZIEH FIX® Pull Screw 1204** „Special” (red, Ø 5.5 mm)  
– for extraction of lock cylinders



The use of our washer (order no. 1200) in connection with our ZIEH-FIX® Pull Screws extends the life expectancy of the ZIEH-FIX® Bell regarding the holding time of the pulling unit considerably.

The washer is re-usable and is placed underneath the Pull Screw.

## Tearing

### Profile cylinder



Picture 2

After insertion of the Pull Screw (picture 2) the ZIEH-FIX® Bell is fixated by attaching its pulling unit on the screw head. The collar nut is now being turned (by hand) until the main unit connects to the fitting or rosette (picture 3).

With the help of a screw driver the collar nut is being tightened until the connecting bar of the lock cylinder breaks off (picture 4 and 5).

Breakage point is always in the area of the shield screw drilling and occurs in two steps. In the first step the area above the shield screw drilling breaks off and in the second step the area below. As soon as the first step (part-breakage of bar) can be heard as a noise or be seen as an abrupt movement the ZIEH-FIX® Bell is being loosened by turning the collar nut left and refitted and tightened as described above.

Refitting of the tool is necessary as the Pull Screw is deformed by the pulling power of the downward tilted lock cylinder.

On occasion this side movement can cause the breakage of the Pull Screw.

After removing the broken pieces (picture 6) the mortise lock can be operated with a profile cylinder locking devise (picture 7).

### Round cylinder

The approach is identical to the profile cylinder. The refitting of the tool after part breakage is not necessary.

The mortise lock can be operated with a screw driver or another appropriate tool after the removal of the broken pieces.



Picture 5



Picture 3



Picture 6



Picture 4



Picture 7

### Note

After tearing of the lock cylinder all broken pieces have to be removed from the keyway and the function of the mortise lock has to be checked.

The pulling power can damage the mortise lock, which would make an exchange necessary.



## Plug Extraction



Picture 8

### Profile cylinder

Before fitting the pull screw (picture 9) the plug extractor plate for profile cylinders, order no. 1003, has to be fixated (picture 8).

It is important that the bore hole is aligned with the cylinder core and the milled notch of the extractor plate points towards the lock cylinder.

Now the ZIEH-FIX® Bell can be fitted to the screw head of the pull screw.



Picture 9

The collar nut is being turned (by hand) until the basic unit is hooked to the extractor plate (picture 10).

Tighten the collar nut with a ratchet (picture 11) until the locking pins and the safety ring shear off or rather the core has been removed completely from the lock cylinder (picture 12).

After removing the broken pieces from the core drilling the lock cylinder can be opened with a screw driver or another adequate tool. The screw driver is being guided through the core drilling towards the locking device and turned (picture 13).



Picture 10

### Note

To avoid shifting of the extractor plate the plate can be fixated with double-sided adhesive if the lock cylinder squares up to the fitting.

The mortise lock needs to be checked for loose fallen in parts and these must be removed.

Plug extraction does not damage the mortise lock.



Picture 11



Picture 12



Picture 13





## Spare parts

Order no.	Description
1006	Thrust block
1007	Feed shaft including set screw and collar nut
1008	Inner part for plug extractor shaft (pulling unit)
9715-K	Pressure spring, short

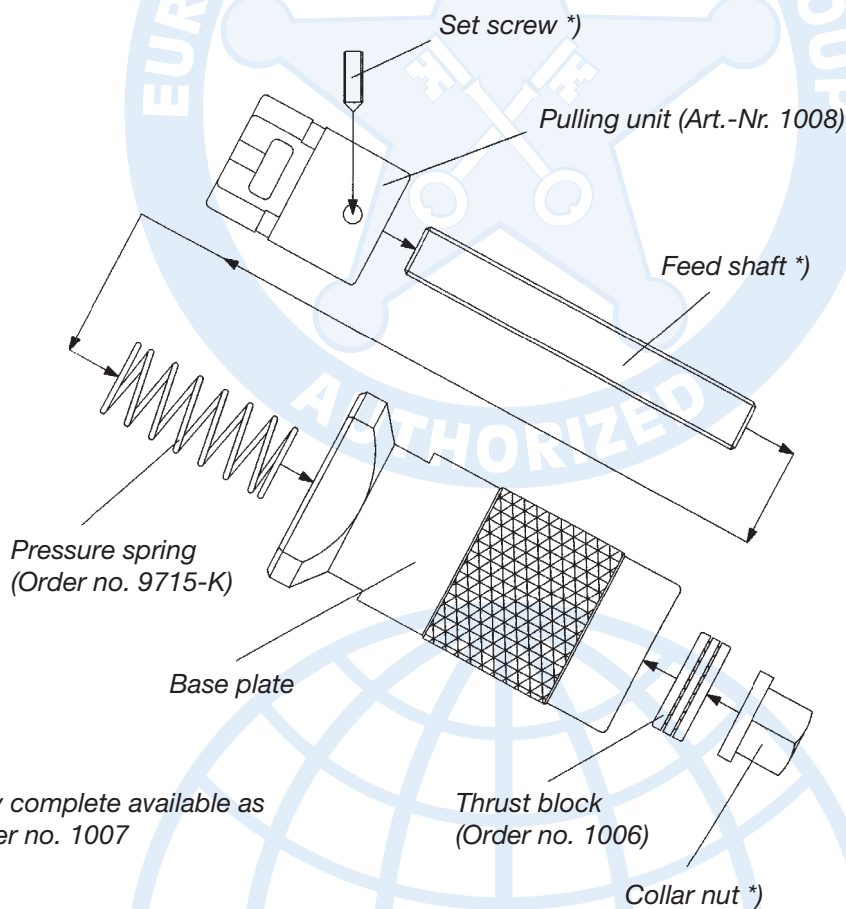

\*) Only complete available as  
Order no. 1007

## Optional parts (not included in delivery)

Order no.	Description
1003	ZIEH-FIX® Plug Extractor Plate for profile cylinder locks
1004	ZIEH-FIX® Plug Extractor Plate for round cylinder locks
1200	Washer for ZIEH-FIX® Pull Screws
1202	ZIEH-FIX® Pull Screw "Extra"
1203	ZIEH-FIX® Pull Screw "Super"
1204	ZIEH-FIX® Pull Screw "Spezial"